

FITTING INSTRUCTION

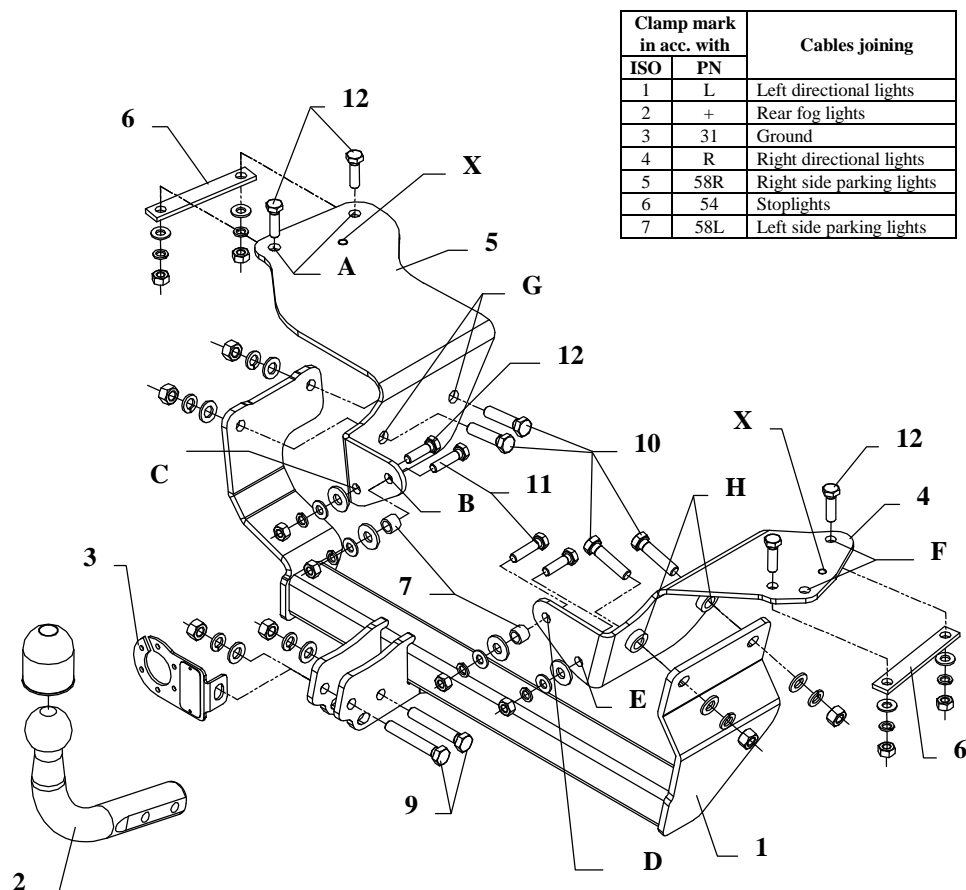

This towbar is designed to assembly in following cars:
ALFA ROMEO 147, 3/5 doors, produced since 2000, catalogue no. **AL37**
 and is prepared to tow trailers max total weight **1300 kg** and max vertical load **60 kg**.

From manufacturer

Thank you for buying our product. Their reliability has been confirmed in many tests. Reliability of towbar depends also on correct assembly and right operation. For this reasons we kindly ask to read carefully this instruction and apply to hints.

The towbar should be install in points described by a car producer.

The instruction of the assembly

- For mounting the towbar is necessary:
 - disassemble the bumper, the exhaust box, the heat-proof casing, the carpets from the floor and the sides, of the carrier.
- Take out the anti-noise mat from the right and left side of the carrier. Under this elements, are placed by factory the fitting points. Drill to $\varnothing 10\text{mm}$.
- To this prepared places apply the left and right brackets (pos. 4 and 5). Place this elements by the appointed pegs, showed "X" on the drawing. Put on, on the previously bored holes $\varnothing 10\text{mm}$.
- This brackets (pos. 4 and 5) must to be carefully arranged, and then by the holes (pos. A,B,C,D,E and F) drill to $\varnothing 11\text{mm}$, and by (pos. G and H) drill to $\varnothing 13\text{mm}$.
- Ream the holes (pos. B and D) from the outside of the rear plate of the car, by drill $\varnothing 17\text{mm}$. Set in this holes the distance sleeves $\varnothing 17\text{mm}$, L=13mm.
- From the bottom of the car place the main bar of the towbar (pos. 1) and twist the bolts M12x50mm (pos. 10) and all remaining units, look the drawing.
- Mount the heat-proof casing, the exhaust box, the bumper, and the remaining elements previously disassembled.
- To the installed bar, mount the tow-ball (pos. 2) with the socket plate (pos. 3) using bolts M12x75mm (pos. 9).
- Tighten all bolts according to the torque shown in the table.
- Connect the kit wires to the electric installation, in accordance with the instructions of the car.
- Complete the possible decreases of the paint cover of towbar, originate during the mounting.

Torque settings for nuts and bolts (8,8):	
M 8 - 25 Nm	M 10 - 55 Nm
M 12 - 85 Nm	M 14 - 135 Nm











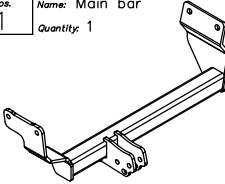



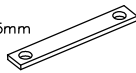

NOTE

After install the towbar you should get adequate note in registration book (at authorised service station).The car should be equipped with:

- Indicators
- Tow mirrors

After 1000km check all bolts and nuts. The ball of towbar must be always kept clear and conserve with a grease.

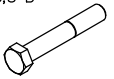
Towbar accessories:

Pos. 1 Name: Main bar Quantity: 1 	Pos. 5 Name: Left bracket Quantity: 1 	Pos. 10 Name: Bolt 8,8 B Quantity: 4 Dim.: M12x50mm 	Pos. 15 Name: Plain washer Quantity: 6 Dim.: Ø 13 mm 
Pos. 2 Name: Tow ball Quantity: 1 	Pos. 6 Name: Flat bar Quantity: 2 Dim.: 130x20x5mm 	Pos. 11 Name: Bolt 8,8 B Quantity: 2 Dim.: M10x40mm 	Pos. 16 Name: Plain washer Quantity: 8 Dim.: Ø 10,5 mm 
Pos. 3 Name: Socket plate Quantity: 1 	Pos. 7 Name: Distance sleeve Quantity: 2 Dim.: Ø17.2xØ2.35mm L=13mm 	Pos. 12 Name: Bolt 8,8 B Quantity: 6 Dim.: M10x35mm 	Pos. 17 Name: Spring washer Quantity: 6 Dim.: Ø 12,2 mm 
Pos. 4 Name: Right bracket Quantity: 1 	Pos. 8 Name: Washer Quantity: 4 Dim.: Ø30xØ10.5x2.5mm 	Pos. 13 Name: Nut 8 B Quantity: 6 Dim.: M12 	Pos. 18 Name: Spring washer Quantity: 8 Dim.: Ø 10,2 mm 
	Pos. 9 Name: Bolt 8,8 B Quantity: 2 Dim.: M12x75mm 	Pos. 14 Name: Nut 8 B Quantity: 8 Dim.: M10 	Pos. 19 Name: Ball cover Quantity: 1 



PPUH AUTO-HAK S.J.

Produkcja Zaczepów Kulowych
Henryk & Zbigniew Nejman
76-200 SŁUPSK ul. Słoneczna 16K
tel/fax (059) 8-414-414; 8-414-413
e-mail: office@autohak.com.pl
www.autohak.com.pl

Towing hitch (without electrical set)

Class: **A50-X** Cat. no. **AL37**

Designed for:

Manufacturer: **ALFA ROMEO**

Model: **147**

Type: **3/5 doors**

produced since 2000

Technical data:

D-value: 6,35 kN

maximum trailer weight: **1300 kg**

maximum vertical cup load: **60 kg**

Approval number acc. to regulations EKG/ONZ 55.01: E20-55R-01 0937

Foreword

This towbar is designed according to rules of safety traffic regulations. The towing hitch is a safety component and can be install only by qualified personnel. Any alteration or conversion of the towing hitch is prohibited and would lead to cancellation of design certification. Remove insulating compound and underseal from vehicle (if present) in the area of the matting surfaces of the towing hitch.

The vehicle manufacturer's specifications regarding trailer load and max. vertical cup load are decisive for driving whereat values for the towing hitch cannot be exceeded.

D-value formula:

$$\frac{\text{Max trailer weight [kg]} \times \text{Max vehicle weight [kg]}}{\text{Max trailer weight [kg]} + \text{Max vehicle weight [kg]}} \times \frac{9,81}{1000} = D \text{ [kN]}$$